



**Model Number**

**VCS110-2533**

Color sensor  
with two M12 x 1 connectors

**Features**

- Color saving by TEACH-IN key
- Programmable up to 10 channels
- Color tolerances memorizable
- Light source white-light LED
- Signal outputs direct or binary coded
- For glass fiber optics or for plastic fiber optics

**Dimensions**

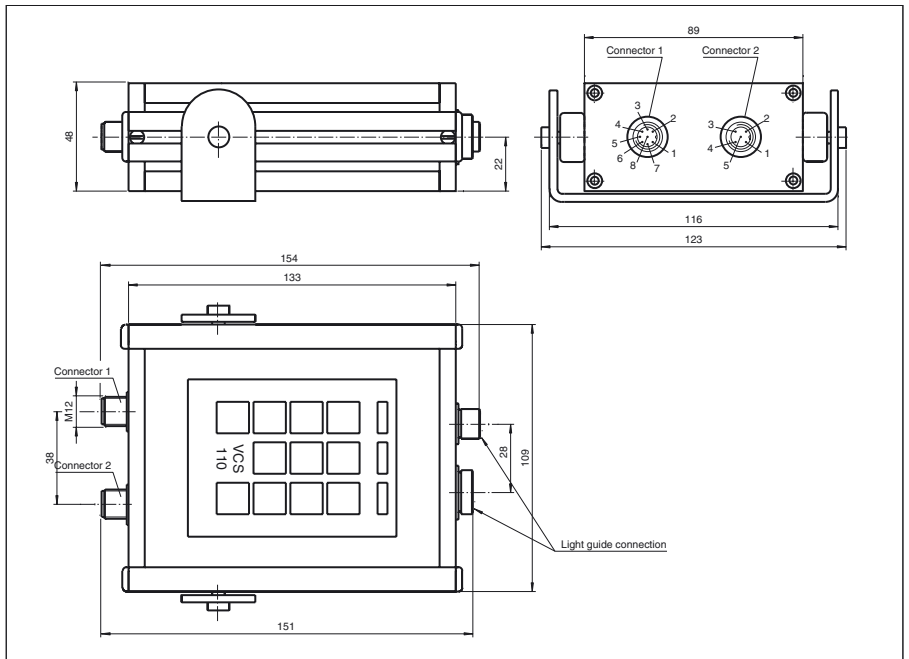

**Electrical connection**

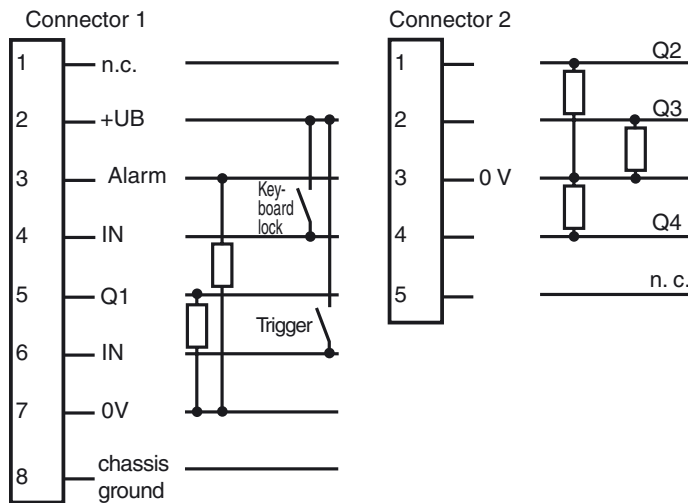

Release date: 2006-08-11 10:07 Date of issue: 2011-01-25 132235\_ENG.xml

Subject to modifications without notice

Pepperl+Fuchs Group  
www.pepperl-fuchs.com

USA: +1 330 486 0001  
fa-info@us.pepperl-fuchs.com

Germany: +49 621 776-4411  
fa-info@pepperl-fuchs.com

Copyright Pepperl+Fuchs  
Singapore: +65 6779 9091  
fa-info@sg.pepperl-fuchs.com

## Technical data

### General specifications

Sensor range	max. 100 mm
Light source	LED
Light type	modulated white light
Light spot representation	approx. 5 mm ... 60 mm (depends on sensor range and fiberoptic cable)
Approvals	CE, UL

### Indicators/operating means

Operating display	LED for power on
Function display	one yellow LED each per colour channel lights up if colour detected, three LEDs as adjustment accessories
Controls	membrane keys

### Electrical specifications

Operating voltage	$U_B$	18 ... 30 V DC
Ripple		10 %
No-load supply current	$I_0$	max. 200 mA

### Input

Function input	Trigger, keyboard disable
----------------	---------------------------

### Output

Output of the pre-fault indication	PNP, active in TEACH-IN mode or if all value memory slots are empty	
Switching type	according to $+U_B$ switching, if color detected	
Signal output	5 PNP, short-circuit proof, each with two assigned value memory slots The last activated channel is exported.	
Switching voltage	max. 30 V DC	
Switching current	max. 200 mA per output	
Switching frequency	$f$	25 Hz
Response time		20 ms
De-energized delay	$t_{off}$	20 ms

### Standard conformity

Standards	EN 60947-5-2
-----------	--------------

### Ambient conditions

Ambient temperature	-10 ... 50 °C (14 ... 122 °F)
Storage temperature	-20 ... 75 °C (-4 ... 167 °F)

### Mechanical specifications

Protection degree	IP65
Connection	M12 connector, 8-pin and M12 connector, 5 pin
Material	
Housing	aluminium
Optical face	Fiberoptics
Mass	300 g

### Approvals and certificates

CCC approval	Products with a maximum operating voltage of $\leq 36$ V do not bear a CCC marking because they do not require approval.
--------------	--

### Detection ranges

VCS110

Fibre optics:

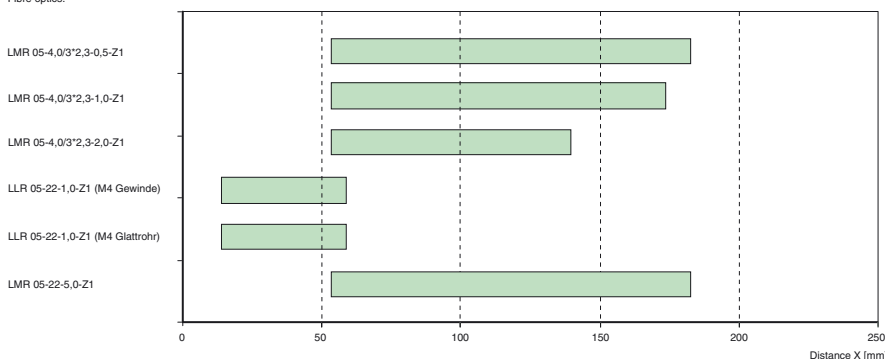

**Note:** In practice, working distances are considerably reduced in the case of non-vertical incidence and darker colors

## Curves/Diagrams

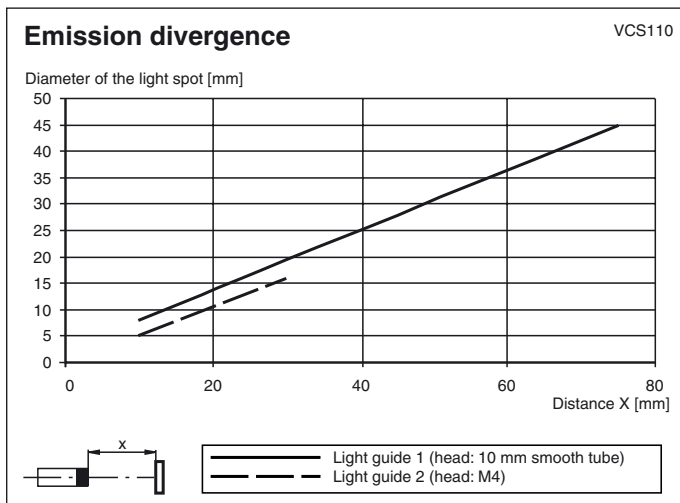

## Function

The VCS is a colour sensor which is used to distinguish up to 10 colours. The colours can be programmed using 10 channels with the TEACH-IN key on the evaluation and control unit. A long-life white-light LED with greater light intensity is used for lighting.

The light reflected by the test object returns to the head of the fibre optic, which forwards it to the three-channel receiver. There the spectral portions of red, green and blue (RGB) are evaluated, digitised and processed in the microprocessor of the control interface.

To achieve contiguous colour detection, colour filters are used in the three-range procedure for red, green and blue.

On the output side, a model is available (VCS110- 5K) with five direct outputs for five different colours that can be selected from 10 saved colours, and a design (VCS110-10K) is also available with binary-coded outputs for up to 10 different colours.

## Colour spectrum

The frequency range or the colour spectrum of the VCS110 is designed so that the evaluation takes place in the visible range of the spectrum. The wave range from 400 nm to about 700 nm is covered without any gaps.

## TEACH-IN

The distance between the light wave guide end-piece and the test object must be adjusted so that the LED lights up with "OK". Depending on the type of light wave guide, the detection ranges are between 10 mm and 100 mm.

To put the device in TEACH-IN mode, press the INP key. The LED of the INP key flashes. Press the desired memory key. The corresponding LED flashes and the sampled colour undergoes TEACH-IN.

## Relearning and adjusting of the tolerance ranges

Relearning is recommended for variations of the colour and for detection range. To do this, repeat the procedure described in the previous section (Teach-in). A tolerance field is automatically assigned to the teach-in colour template. Performing Teach-in twice for the same colour in a single memory slot at different distances results in Teach-in for the entire distance range.

## Complete the Teach-in process:

In order to complete the Teach-in process, press the INP key again. The corresponding LED stops flashing and the device is in evaluation mode. As long as the device is in Teach-in mode, the alarm output is set.

## Evaluation

## VCS110-10K:

All 10 memory slots can be used separately and 10 different colours can be evaluated. The outputs are coded in binary in the following manner.

Memory slots	Output (Q)
	4 3 2 1
1	0 0 0 1
2	0 0 1 0
3	0 0 1 1
4	0 1 0 0
5	0 1 0 1
6	0 1 1 0
7	0 1 1 1
8	1 0 0 0
9	1 0 0 1
10	1 0 1 0

**VCS110-5K:**

Teach-in can be performed for colours on all 10 channels. Two channels are assigned to each output, but only one channel can be activated. Press the desired memory key. The LED flashes and the output assigned to the memory slot is active. Then the output of the not selected memory cell is blocked.

Channel	Output (Q)
1+6	1
2+7	2
3+8	3
4+9	4
5+10	5

**Alarm output:**

If the device is in TEACH-IN mode or all memory slots in the channel are empty, the alarm output is set.

**Delete memory****Delete the memory content of all memory slots:**

The VCS110 is placed in the evaluation mode. Continue pressing the INP key until all LEDs are lit and have gone out again. The memory slots are deleted and the device is back in evaluation mode. If the INP key is released while the LEDs are lit, all memory slots are deleted, the device is back in TEACH-IN mode and the alarm output is set.

**Delete the memory content of a memory slot:**

Do not press the INP key, the device remains in evaluation mode. Continue pressing the memory key of the memory slot to be deleted until the LED changes from flashing to being lit up continuously.

**Adjusting and Aligning**

If the VCS110 is receiving a power supply 18 V ... 30 V, the distance between the colour mark to be detected and the output of the fibre optic is elected until the LED lights up with "OK". For glossy surfaces, you should select a detection angle of about 30° ... 60°.

**Keyboard disable**

The keyboard disable can be activated by applying +U<sub>ST</sub> to connector 1/pin4. No more keys can be pressed, but it is possible to continue the evaluation.

**Ground:**

The housing of the VCS110 can be grounded via connector 1, pin 8.

**System accessories**

Model number	Length	Description
V17-G-2M-PUR		connection cable 2m, 8-pin
V15-G-2M-PUR		connection cable 2m, 5-pin
LMR 05-22-5,0-Z1 VCS110 <sup>1)</sup>	5 m	
LMR 05-22-10.0-Z1 VCS110 <sup>1)</sup>	10 m	
LMR 01-4.0/3*2.3-0.5-Z1 VCS110 <sup>2)</sup>	0.5 m	
LMR 01-4.0/3*2.3-1.0-Z1 VCS110 <sup>2)</sup>	1.0 m	
LMR 01-4./3*2.-2.-Z1 VCS110 <sup>2)</sup>	2. m	

1) Plastic light guide, reflex with rust-free flexible radiation coating; end sleeve: 85 mm long, diameter: 10 mm on 40 mm length



2) Plastic light guide, reflex with rust-free flexible radiation coating; end sleeve: 50 mm long, diameter: 10 mm

Release date: 2006-08-11 10:07 Date of issue: 2011-01-25 132235\_ENG.xml

Subject to modifications without notice

Pepperl+Fuchs Group  
www.pepperl-fuchs.com

USA: +1 330 486 0001  
fa-info@us.pepperl-fuchs.com

Germany: +49 621 776-4411  
fa-info@pepperl-fuchs.com

Copyright Pepperl+Fuchs  
Singapore: +65 6779 9091  
fa-info@sg.pepperl-fuchs.com