



Model Number

SBL-8-H-SL-3549 100pcs

Background suppression sensor with fixed cable

Features

- Minimal black/white difference
- For installation between the rollers on a roller conveyor
- Can be connected in series
- External valve can be connected
- Protection degree IP65

Product information

Sensors of the SBL series are used to easily control material flow on roller conveyors in material handling and other branches.

The SBL series is a precise background suppression sensor according to the 3 element method. The sensor features superior background suppression and a very good ambient light immunity. Material and transport container of all colors and opacities are reliably detected.

The special design allows the sensor to be mounted between the rollers of a roller conveyor or any other conveying unit. Mounting between the rollers is easy and protects the sensor.

Dimensions

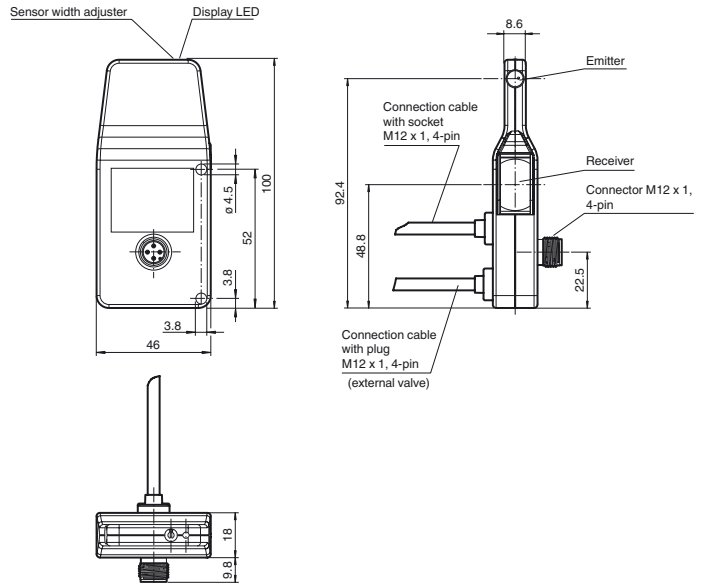

Electrical connection

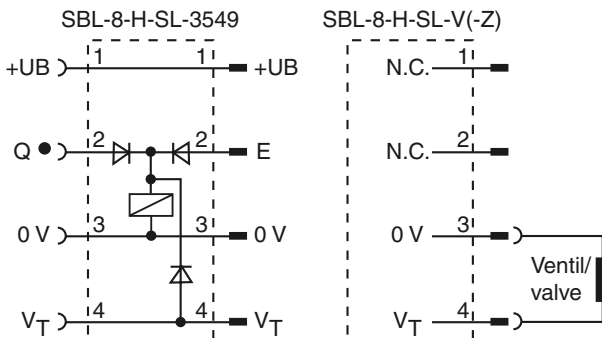

Pinout

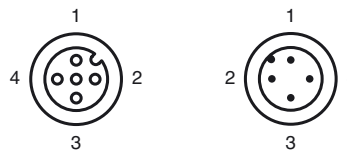

Indicators/operating means

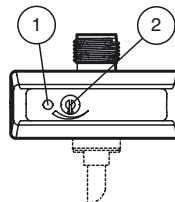

1	Signal display	yellow
2	Sensing range adjuster	

Release date: 2011-02-23 16:52 Date of issue: 2011-02-23 200257_ENG.xml

Subject to modifications without notice

Pepperl+Fuchs Group
www.pepperl-fuchs.com

USA: +1 330 486 0001
fa-info@us.pepperl-fuchs.com

Germany: +49 621 776-4411
fa-info@pepperl-fuchs.com

Copyright Pepperl+Fuchs
Singapore: +65 6779 9091
fa-info@sg.pepperl-fuchs.com

Technical data**General specifications**

Detection range	15 ... 600 mm
Detection range min.	15 ... 250 mm
Detection range max.	15 ... 600 mm
Adjustment range	250 ... 600 mm
Reference target	standard white 200 mm x 200 mm
Light source	IREL
Light type	modulated infrared light , 880 nm
Black/White difference (6%/90%)	< 15 %
Diameter of the light spot	approx. 40 mm at detection range 600 mm
Cascadability	max. 50 sensors per line
Ambient light limit	continuous light 30000 Lux , Fluorescent lamp 5000 Lux

Functional safety related parameters

MTTF _d	1100 a
Mission Time (T _M)	20 a
Diagnostic Coverage (DC)	0 %

Indicators/operating means

Function display	LED yellow: lights when object is detected
Controls	Detection range adjuster

Electrical specifications

Operating voltage	U _B	24 VDC -20% +10%
Ripple		max. 10 %
No-load supply current	I ₀	max. 30 mA

Output

Switching type	dark on	
Signal output	1 PNP, short-circuit protected, reverse polarity protected	
Switching voltage	max. 30 V DC	
Switching current	max. 200 mA	
Switching frequency	f	100 Hz
Response time	5 ms	

Ambient conditions

Ambient temperature	-20 ... 50 °C (-4 ... 122 °F)
Storage temperature	-30 ... 60 °C (-22 ... 140 °F)

Mechanical specifications

Protection degree	IP65
Connection	Connecting cable 1 m with Socket, straight M12 x 1 Connecting cable 0.15 m with Connector, straight M12 x 1
Material	
Housing	plastic
Optical face	plastic lens
Mass	approx. 160 g

Compliance with standards and directives

Directive conformity	EMC Directive 2004/108/EC
Standard conformity	
Product standard	EN 60947-5-2:2007 IEC 60947-5-2:2007
Shock and impact resistance	IEC / EN 60068. half-sine, 40 g in each X, Y and Z directions
Vibration resistance	IEC / EN 60068-2-6. Sinus. 10 -1000 Hz, 10 g in each X, Y and Z directions

Approvals and certificates

UL approval	cULus Listed, Class 2 Power Source, Type 1 enclosure
CCC approval	Products with a maximum operating voltage of ≤36 V do not bear a CCC marking because they do not require approval.

Accessories**OMH-SBL-01**

Mounting bracket for sensors of SBL series

V1-G-2M-PVC

Cable socket, M12, 4-pin, PVC cable

V1-G-5M-PVC

Cable socket, M12, 4-pin, PVC cable

V1-W-2M-PUR

Cable socket, M12, 4-pin, PUR cable

V1-W-5M-PUR

Cable socket, M12, 4-pin, PUR cable

V1S-TEE-V1/V1S

T-Distributor, M12 connector to M12 socket/connector

Schraubendreher 0,5 x 3,0 mm

Screwdriver

Additional accessories can be found in the Internet.

Curves/Diagrams

Difference in detection distance

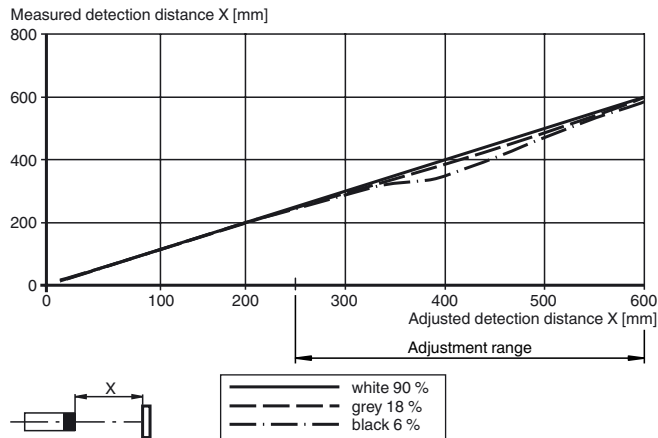

Additional Information

Intended use:

The transmitter and receiver are located in the same housing for direct detection sensors with background masking. Marking of objects outside the detection range is achieved by arranging the angle between the transmitter and receiver (2 receiver elements).

Objects are detected independently of the structure and colour of the surface.

The special design of the sensors makes it possible to install them between two rollers in the roller back-up conveyor systems under the material that is being moved. This allows for installation that saves space and prevents mechanical damage of the sensor caused by material being conveyed.

Mounting instructions:

The sensors can be directly fastened in place with the pass-through bore holes or can be attached with a support bracket or a clamp (the last two are not included in delivery).

The surface underneath must be flat to prevent the housing from moving when it is tightened into position. We recommend securing the nut and screw in place with spring washers to prevent the sensor from going out of adjustment.

For versions SBL-8-H-SL, -V, -Z

As many as 25 sensors can be cascaded with the aid of just one power supply. A solenoid valve is energised if the corresponding sensor itself or its predecessor in the cascade does not see any object.

It is also possible to energise the valves of all sensors included in the cascade with block movement (V_T). To do this, apply the positive supply voltage (+UB) on the input V_T of the first sensor.

Adjustment:

Align the sensor to the background. If the yellow LED is lit, the detection range should be reduced with the detection range adjuster until the yellow LED goes out.

Object detection:

Position the object to be detected in the path of the beam. If the object is detected, the yellow LED lights up.

If it does not light up, the detection range must be further adjusted on the potentiometer until it lights up when an object is detected.

Version SBL-8-H-SL-V-Z only:

The two adjusting mechanisms on the front side of the sensor can be used separately for timer functions for the switching on or switching off process.

This results in a delay defined by the adjuster between the change of state (object detected -> object not detected or vice-versa) and the switching process. The duration of the delay can be set for up to 2 seconds.

Cleaning:

We recommend cleaning the optical surface and checking all connections at regular intervals.

Note:

Use a screwdriver to adjust the sensing range. We strongly recommend to use the screwdriver given in the accessories section.