



Model Number

ML7-8-H-140-RT/59/65a/110/115a

Background suppression sensor with 0.5 m fixed cable and M8 connector, 3-pin

Features

- Miniature design
- Reliable detection of all surfaces, independent of color and structure
- Minimal black/white difference
- Precision background suppression, adjustable
- Clearly visible function indicators
- Short circuit and low voltage indicator
- Certified by ECOLAB

Product information

Small, robust, effective, and reliable - these are the properties of the ML7 sensor series. Due to their small size, number of versions, and two different lens positions, they are particularly suited for installation in tight spaces. The robust design and high quality of Pepperl+Fuchs mean they can also be used under harsh environmental conditions. The efficient technology, switching frequencies up to 1000 Hz, high resistance to ambient light, and 4-in-1 output make the series suitable for non-contact object detection.

Release date: 2011-03-01 15:47 Date of issue: 2011-03-01 2 19039_ENG.xml

Dimensions

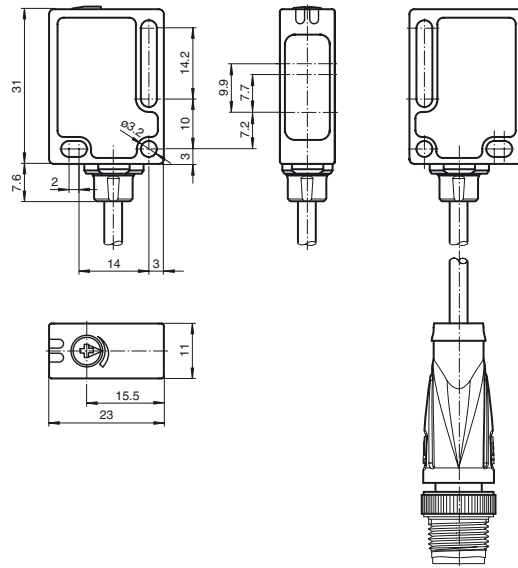

Electrical connection

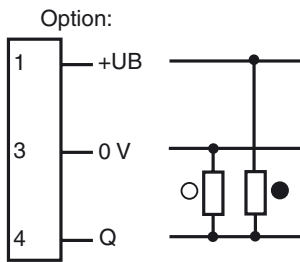

- = Light on
- = Dark on

Pinout



Indicators/operating means

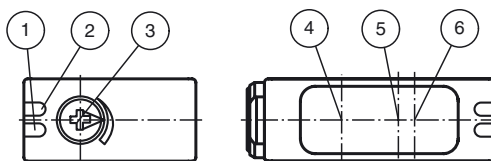

1	Operating display	green
2	Signal display	yellow
3	Sensing range adjuster	
4	Emitter	
5	Receiver TW min.	
6	Receiver TW max.	

Technical data**General specifications**

Detection range	5 ... 140 mm
Detection range min.	5 ... 25 mm
Detection range max.	13 ... 140 mm
Adjustment range	25 ... 140 mm
Reference target	standard white, 100 mm x 100 mm
Light source	LED
Light type	modulated visible red light
Black/White difference (6%/90%)	< 10 %
Diameter of the light spot	approx. 5 mm at detection range 120 mm

Indicators/operating means

Operating display	LED green, statically lit Power on ; Undervoltage indicator: Green LED, pulsing (approx. 0.8 Hz) , short-circuit : LED green flashing (approx. 4 Hz)
Function display	LED yellow: lights when object is detected
Controls	Detection range adjuster

Electrical specifications

Operating voltage	U_B	10 ... 30 V DC , class 2
Ripple		max. 10 %
No-load supply current	I_0	< 20 mA

Output

Switching type	light/dark on	
Signal output	1 push-pull output, short-circuit protected, reverse polarity protected	
Switching voltage	max. 30 V DC	
Switching current	max. 100 mA	
Switching frequency	f	1 kHz
Response time		500 μ s

Ambient conditions

Ambient temperature	-20 ... 60 °C (-4 ... 140 °F)
Storage temperature	-40 ... 75 °C (-40 ... 167 °F)

Mechanical specifications

Protection degree	IP67 / IP69K
Connection	500 mm fixed cable with 3-pin, M8 x 1 connector
Material	
Housing	PC (glass-fiber-reinforced Makrolon)
Optical face	PMMA
Mass	approx. 10 g

Compliance with standards and directives

Standard conformity	
Product standard	EN 60947-5-2:2007 IEC 60947-5-2:2007

Approvals and certificates

Protection class	II, rated voltage \leq 50 V AC with pollution degree 1-2 according to IEC 60664-1
UL approval	cULus

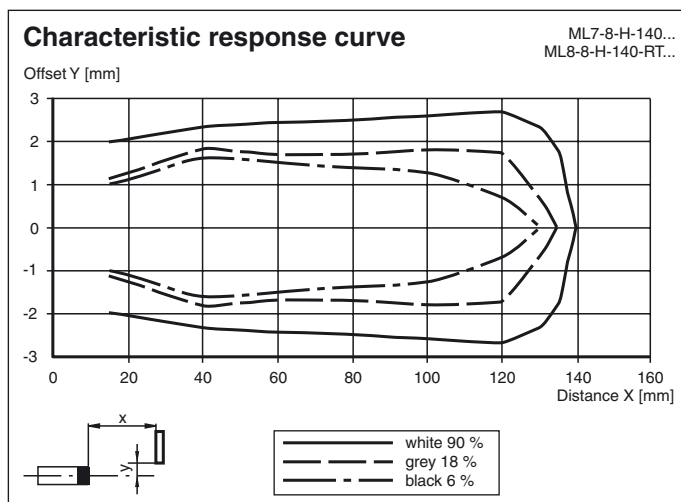
Curves/Diagrams**Accessories****Montagekit OMH-ML7-01**

Mounting set consisting of bracket OMH-ML-01 sheet ONH-ML7-03, and fastening material

Montagekit OMH-ML7-02

Mounting set consisting of bracket OMH-ML-02 sheet ONH-ML7-03, and fastening material

OMH-ML7-01

Mounting bracket

OMH-ML7-02

Mounting bracket

OMH-ML7-03

Fixing plate

Suitable cable sockets can be found in the Internet

Curves/Diagrams

