



MLV11-8-LAS-150/47/112

Diffusive sensor

MLV11-8-LAS-150/47/112

with 5-pin M12 connector, 90° adjustable position

CE



Laser Class II



- ◆ Energetic diffuse type sensor for detection of small objects (Ø 0.1 mm)
- ◆ Automatic adjustment of switching points (sensitivity) via TEACH-IN
- ◆ Visible red light, pulsed LASER light
- ◆ Multifunction input
- ◆ Protection degree IP68
- ◆ Boost-Mode - approx. 4 times the brightness of the transmitted light as an aid in adjustment

Release date: 2006-02-20 15:34 Date of issue: 2006-02-20 421565_ENG.xml

General specifications

Detection range	0 ... 150 mm
Light source	laser diode
Approvals	CE
Laser class	2
Adjustment range	50 ... 150 mm
Reference target	standard white 10 mm x 10 mm
Light type	red, modulated light Laser class 2, eyesafe
Diameter of the light spot	0.1 mm at a distance of 60 mm ± 2
Ambient light limit	10000 Lux

Indicators/operating means

Operating display	LED green
Function display	TEACH-IN: LED green flashing switching state: LED yellow pre-fault indicator: LED red flashing
Operating elements	membrane keys for setting sensitivity and TEACH IN

Electrical specifications

Operating voltage	10 ... 30 V DC
Ripple	10 %
No-load supply current I_0	≤ 25 mA
Time delay before availability t_v	≤ 50 ms

Input

Test input	inactive: ≤ 3 V or unwired; active: ≥ 7 V
------------	---

Output

Output of the pre-fault indication	pnp, dynamic/static configurable
Switching type	light/dark switching
Signal output	2 switch outputs pnp, parameterisable as - NO/NC (antivalent) - NO and pre-fault indication - NC and pre-fault indication
Switching voltage	max. 30 V DC
Switching current	max. 200 mA
Voltage drop U_d	≤ 2.5 V
Switching frequency f	≤ 1000 Hz
Response time	≤ 0.5 ms
Timer function	parameterisable

Standard conformity

Standards	EN 60947-5-2
-----------	--------------

Ambient conditions

Ambient temperature	-10 ... 40 °C (263 ... 313 K)
Storage temperature	-40 ... 70 °C (233 ... 343 K)

Mechanical specifications

Protection degree	IP68
Connection	5-pin M12 x 1 connector, 90° adjustable position
Material	
Housing	PBT
Optical face	scratch resistant plastic pane
Mass	60 g

Release date: 2006-02-20 15:34 Date of issue: 2006-02-20 421565_ENG.xml



MLV11-8-LAS-150/47/112

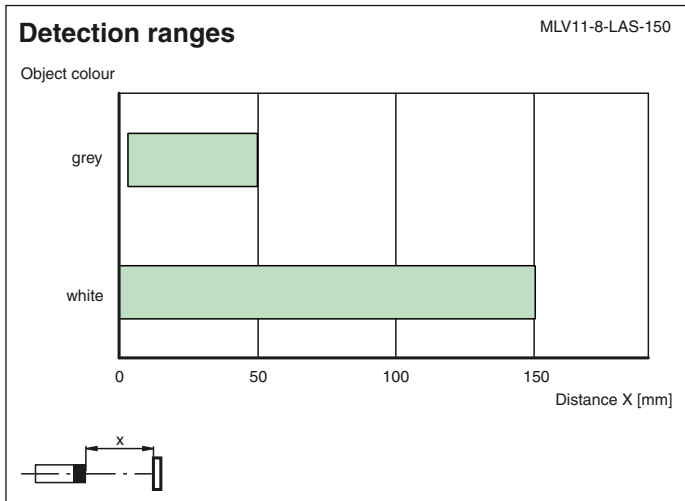
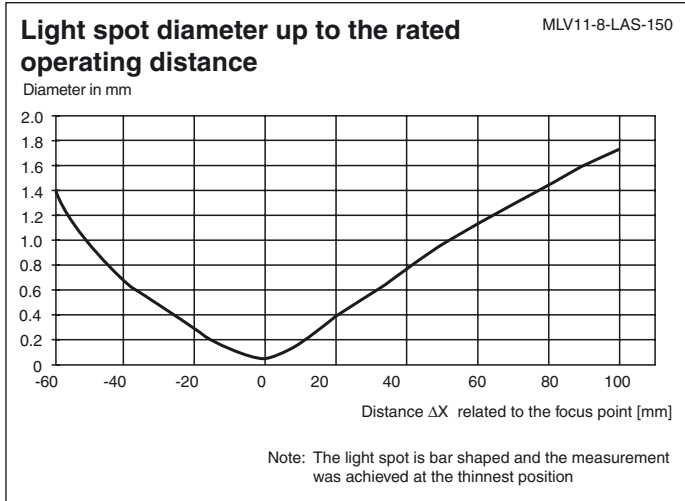

Dimensions

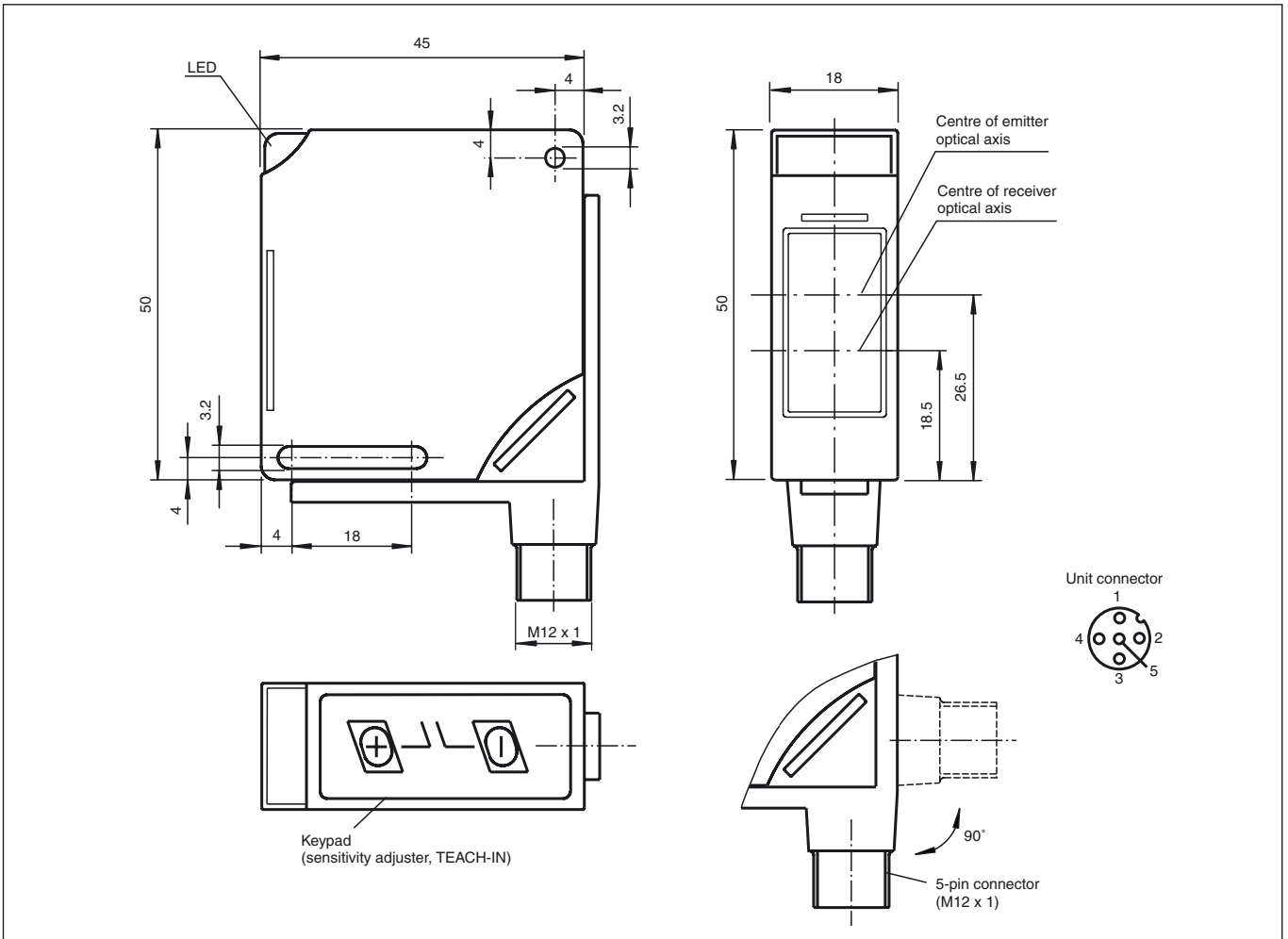

Electrical connection

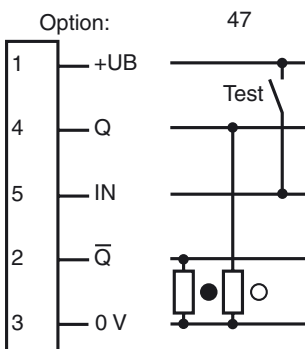

Release date: 2006-02-20 15:34 Date of issue: 2006-02-20 421565_ENG.xml

○ = light on, ● = dark on