

Features

- 19" TFT display w/ optional touch screen
- Seams continuously welded and ground smooth (Type 4/4X, IP66)
- Various keyboard/mouse options
- 100 mm VESA mount
- Class I/Div 2, ATEX Zone 2 approved
- 1.6 GHz Intel® Atom™ processor or 1.5 GHz Core™ 2 Duo

Application

The PC919 operator workstation is designed for continuous use in harsh environments such as manufacturing, oil & gas, and chemical applications.

The PC919 series features a 1.6 GHz Intel® Atom™ processor or a 1.5 GHz Core™ 2 Duo with available 80 GB SSD storage.

The compact housing design allows for easy mounting using the industry standard 100 mm VESA mount.

This 19" PC operator workstation features an optional touchscreen and keyboard with various mouse options.



Connection

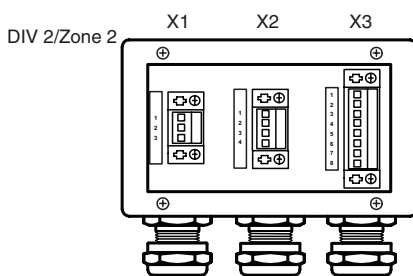

General Purpose

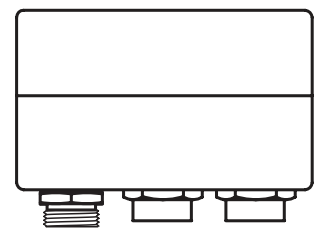

X1 Terminals	AC	DC
1.1	L	+
1.2	N	-
1.3	GND	GND

X2 Terminals	Description
2.1	VCC RD
2.2	D+ GN
2.3	D- WH
2.4	GND BK

X3 Terminals	Description
3.1	BI_DA + WH/GN
3.2	BI_DA - GN
3.3	BI_DB + WH/OR
3.4	BI_DC + BU
3.5	BI_DC - WH/BU
3.6	BI_DB - OR
3.7	BI_DD + WH/BN
3.8	BI_DD - BN

Release date 2013-02-14 14:03 Date of issue 2013-02-14 547087_eng.xml

Hardware	
Processor	Intel® Atom™ N270 1.6 GHz or Intel® Core™ 2 Duo 1.5 GHz
RAM	up to 2 GB
Mass storage	80 GB SSD
Supply	
Power consumption	4.0 A max, 100 ... 240 VAC, 50 ... 60 Hz, or 20-30 VDC
Indicators/operating means	
Display	
Screen diagonal	19"
Response time	15 ms
Resolution	1280 x 1024
Color depth	24 bit (16.7 M) color
Contrast	900:1
Brightness	Standard: 300 nit Zone 2: 500 nit
Reading angle	160° in all directions
Life span	Back lamp life: 50,000 hrs typical half life
Input devices	
Touchscreen	5-wire resistive 5-wire hardened resistive
Keyboard	touchpad , optical trackball (50 mm) , joystick connections : USB
Interface	
Interface type	1 x RJ-45 (GB ethernet) , 1 x USB 2.0 , 1 x power
Directive conformity	
Electromagnetic compatibility	
Directive 89/336/EEC	EN55022A, EN61000-6-2, EN61000-3-2, EN61000-3-3
Software	
Operating system	Windows XP Professional SP3 or Windows 7 Ultimate (32-Bit)
Ambient conditions	
Operating temperature	-20 ... 50 °C (-4 ... 122 °F)
Storage temperature	-20 ... 60 °C (-4 ... 140 °F)
Relative humidity	0 ... 90% (noncondensing)
Mechanical specifications	
Protection degree	Type 4X (stainless steel) Type 4 (painted steel) IP66
Material	Main enclosure: painted black steel or 316L stainless steel Main enclosure (rear cover): 6062 anodized aluminum, marine grade
Installation	100 mm (3.9 inch) VESA mount
Mass	Main unit: 13.6 kg (30 lb) without keyboard; 19.1 kg (42 lb) with keyboard
Dimensions	Main enclosure: 566 x 442 x 86 mm (22.3 x 17.4 x 3.4 inches), junction box adds 43 mm (1.7 inches) to depth Keyboard enclosure: 559 x 254 x 51 mm (22.0 x 10.0 x 2.0 inches)
Data for application in connection with Ex-areas	
EC-Type Examination Certificate	
Group, category, type of protection	⊕ II 3G Ex ic nA IIC T4 Gc
International approvals	
ETL Intertek	Class I/Div 2, ABCD, T4

Release date 2013-02-14 14:03 Date of issue 2013-02-14 547087_eng.xml

Dimensions

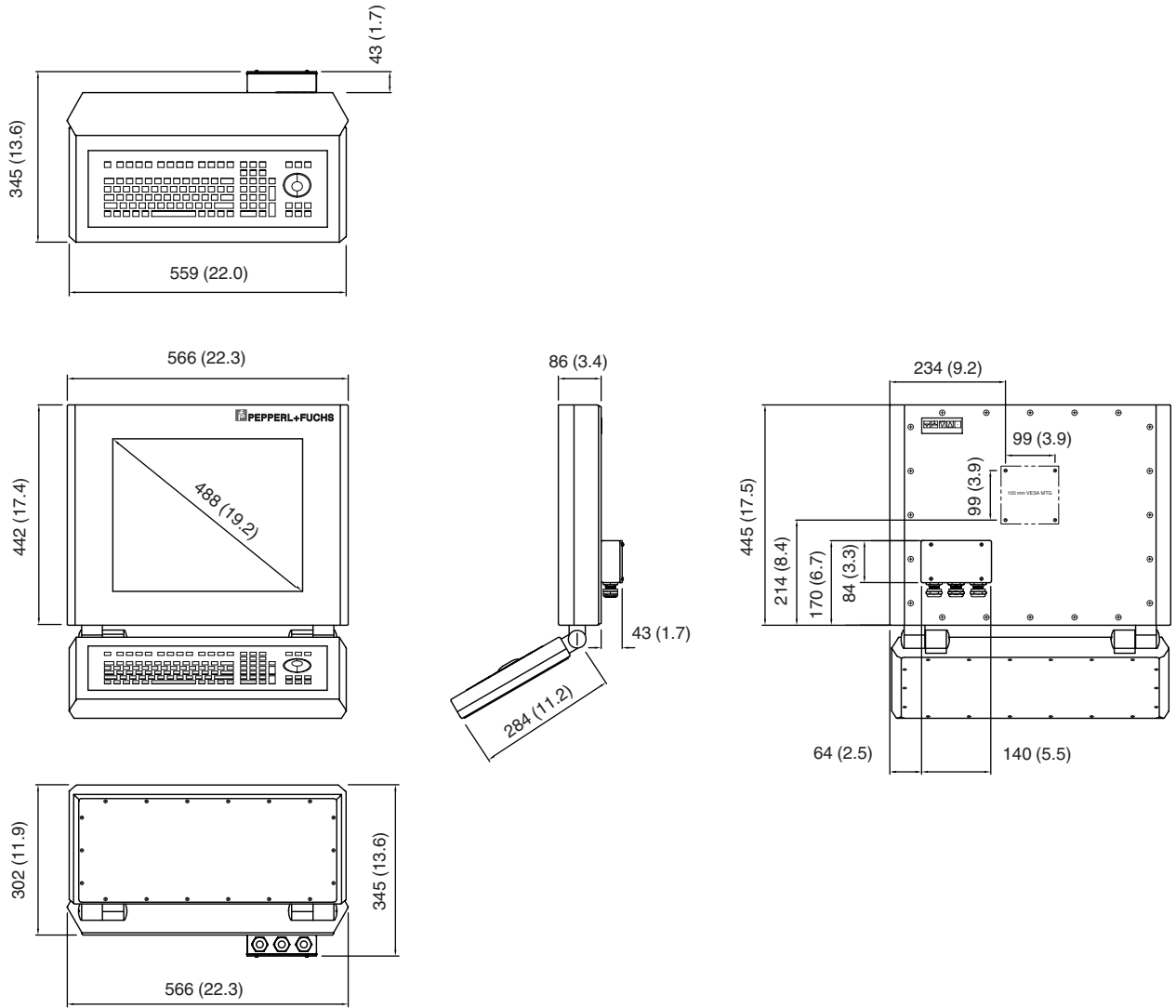

Release date 2013-02-14 14:03 Date of issue 2013-02-14 547087_eng.xml

Type code

P C 9 1 9 A - D 2 - P 5 A C - S P 5 C K 0 L 0 - S 0 - N

<p>Options N No option</p> <p>Special accessories S0 No special accessories</p> <p>Keyboard layout L0 No keyboard, no layout US Keyboard, layout U.S.</p> <p>Keyboard/mouse version K0 No keyboard, no mouse K4 Foil keyboard & touchpad mouse built in K6 Foil keyboard & joystick K8 Foil keyboard & 50 mm optical trackball mouse</p> <p>Keyboard housing C Keyboard & mouse housing, hinge mount, housing, with hinges N No keyboard, no mouse</p> <p>Housing version SP5 IND slimline housing, black painted steel, rear junction box with IP67 connectors (GP only) SS5 IND slimline stainless steel (316L) housing, rear junction box with IP67 connectors (GP only) SP7 IND slimline housing, black painted steel, rear junction box with cable glands (Div 2) SS7 IND slimline stainless steel (316L) housing, rear junction box with cable glands (Div 2)</p> <p>Power supply AC 90 - 260 V AC, 50 - 60 Hz (GP and D2 only) DC 24 V DC</p> <p>Board specifications P8 Intel Core 2 Duo, 1.5 GHz, 2 GB RAM, 80 GB SSD, Windows XP Professional, SP3 multiilingual P9 Atom 1.6 GHz, 2 GB RAM, 80 GB SSD, Windows XP Professional, SP3 multiilingual PA Intel Core 2 Duo, 1.5 GHz, 2 GB RAM, 80 GB SSD, Windows 7 Ultimate (32-Bit) PB Atom 1.6 GHz, 2 GB RAM, 80 GB SSD, Windows 7 Ultimate (32-Bit)</p> <p>Protection D2 Class I, Div. 2 A, B, C, D V3 Class I, Div. 2 A, B, C, D; ATEX Zone 2 GP Industrial, Non-EX</p> <p>Screen type A Antiglare glass front, non-touch R Touch screen, resistive, 5-wire, hardened glass T Touch screen, resistive, 5-wire</p>	<p>PC919 PC monitor, 19.0", SXGA (1280 x 1024 pixels)</p>
---	--