



Model Number

PVM78E

Features

- Up to 30 Bit multiturn
- ATEX approval
- IECEx approval
- Flameproof enclosure
- Removable connection cap

Description

This series of PROFIBUS rotary encoders is based on the modern fast technology of singleturn sampling and the mechanical gear box of the multiturn unit. The absolute encoder corresponds to the PROFIBUS profile for encoders, order no. 3.062. Operation is supported based on Class 1 and Class 2.

For operation based on Class 1, position data and diagnostic data bytes 1 ... 16 are available. In addition, the direction of the code can be selected as either cw ascending (clockwise rotation, code course ascending) or cw descending (clockwise rotation, code course descending).

If the rotary encoder is operated according to Class 2, additional functions to those from Class 1 are available. These include scaling of the resolution per revolution and the overall resolution, as well as the preset function. In addition, expanded diagnostic reporting is supported.

Besides, the rotary encoder offers extended functionalities such as speed transfer, extended scaling functions, programmable limit switches and a commissioning mode.

The removable connecting hood contains a slide switch for setting the terminating resistor and the rotary switches for setting the address. Assign a fixed address and bus termination to the encoder with this switches.

The device is designed for shaft mounting and is available in servo flange or clamping flange design.

Technical data

General specifications

Detection type photoelectric sampling

Functional safety related parameters

MTTF_d 25 a

Mission Time (T_M) 20 a

L_{10h} 7.7 E+9 at 3000 rpm

Diagnostic Coverage (DC) 0 %

Electrical specifications

Operating voltage U_B 10 ... 30 V DC

No-load supply current I₀ max. 230 mA at 10 V DC

max. 100 mA at 24 V DC

Linearity ± 2 LSB at 16 Bit, ± 1 LSB at 13 Bit, ± 0,5 LSB at 12 Bit

Output code Gray code, binary code

Code course (counting direction) programmable,
cw ascending (clockwise rotation, code course ascending)
cw descending (clockwise rotation, code course descending)

Interface

Interface type PROFIBUS

Resolution

Single turn up to 16 Bit

Multiturn up to 14 Bit

Overall resolution up to 30 Bit

Transfer rate 0.0096 ... 12 MBit/s

Standard conformity PNO profile 3.062, RS 485

Connection

Cable Ø9.6 mm, 7-core

Terminal compartment see ordering information

Standard conformity

Protection degree DIN EN 60529, IP66

Climatic testing DIN EN 60068-2-3, no moisture condensation

Emitted interference EN 61000-6-4:2007

Noise immunity EN 61000-6-2:2005

Shock resistance DIN EN 60068-2-27, 100 g, 3 ms

Vibration resistance DIN EN 60068-2-6, 10 g, 10 ... 2000 Hz

Ambient conditions

Operating temperature -40 ... 70 °C (-40 ... 158 °F)

Storage temperature -40 ... 85 °C (-40 ... 185 °F)

Mechanical specifications

Material

Combination 1 housing: anodized aluminium
flange: aluminium, blank
shaft: Stainless steel 1.4401 / AISI 316

Combination 2 (Inox) housing: Stainless steel 1.4404 / AISI 316L
flange: Stainless steel 1.4404 / AISI 316L
shaft: Stainless steel 1.4401 / AISI 316

Mass approx. 2600 g (combination 1)
approx. 3900 g (combination 2)

Rotational speed max. 3000 min⁻¹

Moment of inertia 180 gcm²

Starting torque ≤ 4 Ncm

Shaft load

Axial 60 N

Radial 80 N

Data for application in connection with

Ex-areas

EC-Type Examination Certificate TÜV 11 ATEX 084272X
IECEX TUN 11.0017X

Group, category, type of protection (Ex) II 2G Ex d IIC T5 Gb
(Ex) II 2D Ex tb IIIC T100°C Db IP6X

Directive conformity

Directive 94/9/EC IEC 60079-0:2007 EN 60079-0:2009 IEC 60079-1:2007 EN 60079-1:2007 IEC 60079-31:2008 EN 60079-31:2009

Dimensions

Encoder length L

Version		Length L
Radial cable exit	Clamping flange	109 mm
	Servo flange	109 mm
Axial cable exit	Clamping flange	125 mm
	Servo flange	125 mm

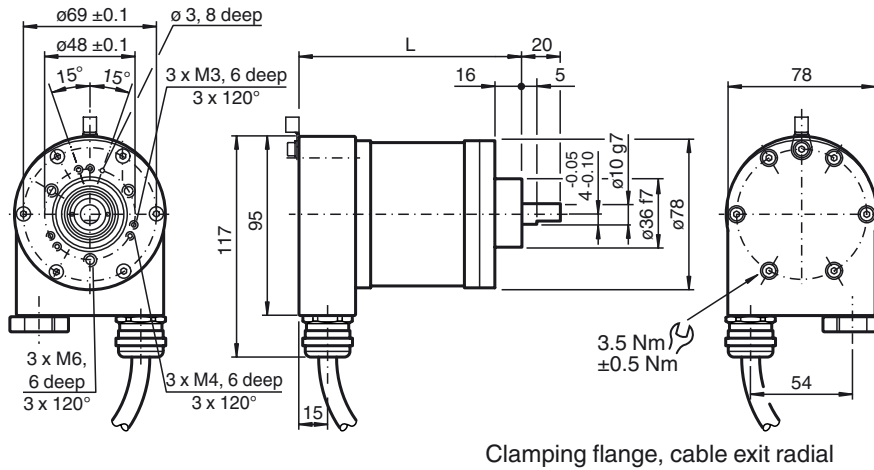

Clamping flange, cable exit radial

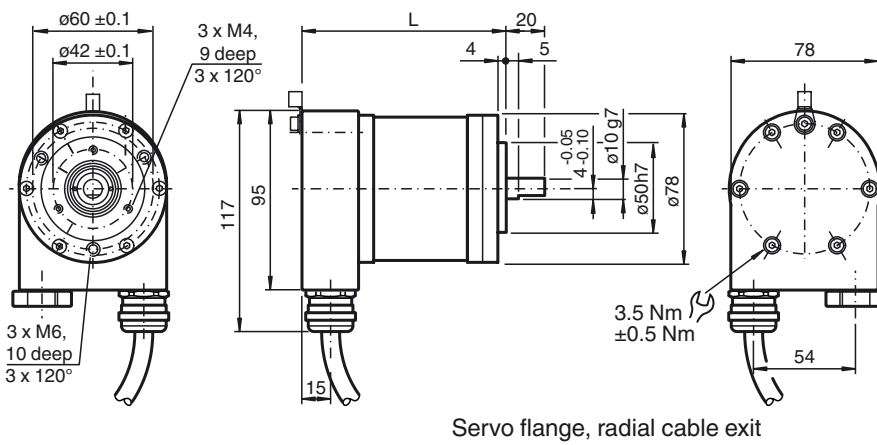

Servo flange, radial cable exit

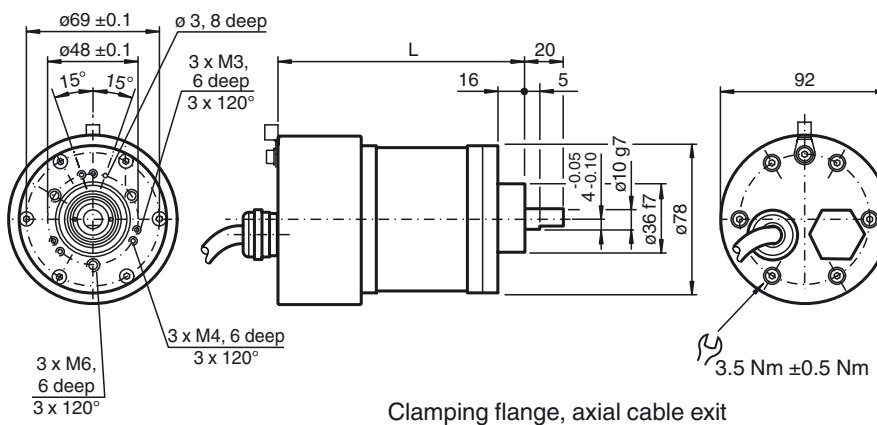

Clamping flange, axial cable exit

Release date: 2012-06-27 15:20 Date of issue: 2012-06-27 t159670_eng.xml

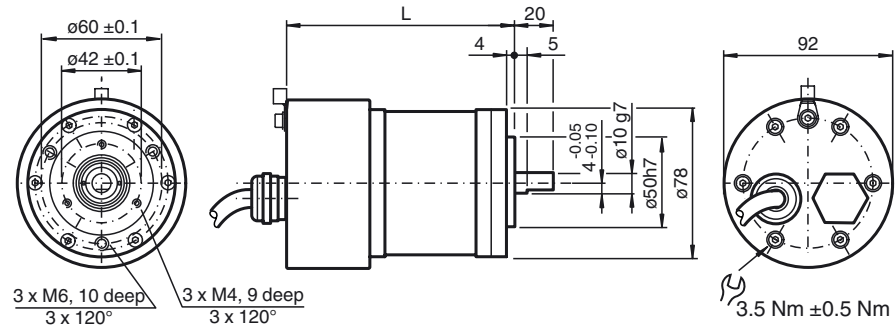

Servo flange, axial cable exit

Shaft 12 mm

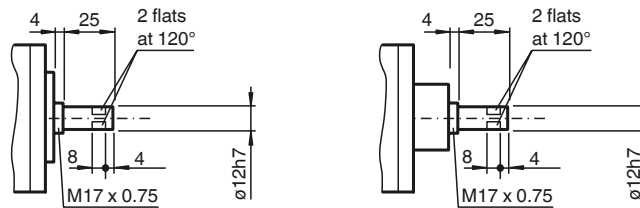

Electrical connection

Signal	Terminal	Cable Ø9.6 mm, 7-core	Description
GND encoder	-	1	- Supply voltage
U_S encoder	+	2	+ Supply voltage
RxD/TxD-P	B	3	Data wire B (pair 1), bus in
RxD/TxD-N	A	4	Data wire A (pair 1), bus in
RxD/TxD-P	B	5	Data wire B (pair 2), bus out
RxD/TxD-N	A	6	Data wire A (pair 2), bus out
potential earth	⊥	GN/YE	

Release date: 2012-06-27 15:20 Date of issue: 2012-06-27 t159670_eng.xml

Indicating and operating elements

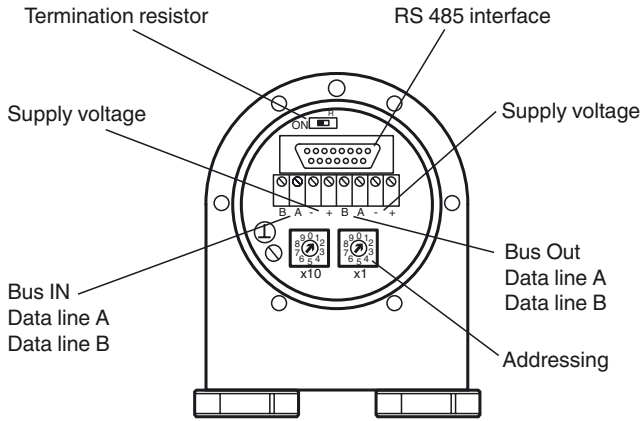

Adjusting the participant address

The participant address can be adjusted with the rotary switches. The address can be defined between 1 and 99, and may only be assigned once.

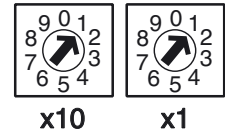

Adjusting the termination resistor

The terminating resistor R_T (121 Ω) can be connected to the circuit by means of the switch:

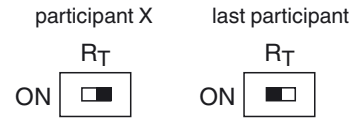

Principle of data transmission

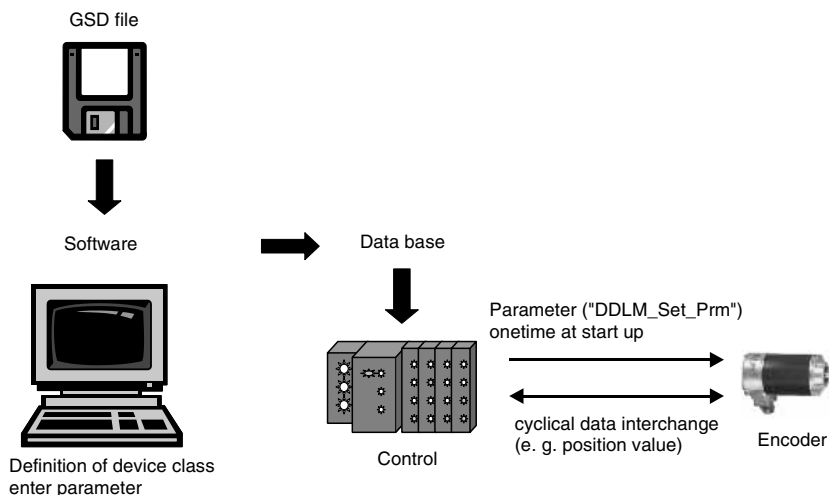

Parameter table encoder classes P+F 2.1 and P+F 2.2

Octet number (Byte)	Parameter	Bit number
1...8	PROFIBUS standard parameters	
9	Direction of rotation	0
	Class 2 functionality	1
	Commissioning Diagnostics	2
	Scaling function	3
	Reserved	4
	Reserved	5
	Activate manufacturer specific parameters (Octet 26)	6
	Reserved	7
10 ... 13	Desired measuring steps (reference: Octet 26, Bit 0 and 1)	
14 ... 17	Overall resolution	
18 ... 25	Reserved	
26	Reference for desired measuring steps	0
		1
	Activate commissioning mode	2
	Reduced diagnosis	3
	Reserved	4
	Activate lower software limit switch	5
	Activate upper software limit switch	6
	Activation of the parameters from Octet 27	7
27 ... 30	Lower limit switch	
31 ... 34	Upper limit switch	
35 ... 38	Physical measuring steps	
39	Reserved	0
	Rotary encoder type (singleturn or multiturn)	1
	Reserved	2
	Reserved	3
	Selection of the unit for speed transfer	4
		5
	Reserved	6
	Reserved	7

Release date: 2012-06-27 15:20 Date of issue: 2012-06-27 t159670_eng.xml

Ordering information



Number of singleturn bits

- 12 4096
- 13 8192
- 16 65536

Number of multiturn bits

- 12 4096
- 14 16384

Housing material

- N Aluminum
- I INOX 1.4404 (AISI 316L)

Output code

- B Binary

Option

- 0 None

Exit position

- A Axial
- R Radial

Connection type

- K2 Cable, 7-wire, 2 m
- K5 Cable, 7-wire, 5 m
- DR Terminal compartment, 2 cable glands
- KR Terminal compartment, 1 cable gland, 1 stopping plug

Flange version

- 1 Clamping flange
- 2 Servo flange

Shaft dimension

- 01 Shaft Ø10 mm x 20 mm
- 02 Shaft Ø12 mm x 25 mm

Option 1

- E Explosion-proof, standard IP66

Functional principle

- M Multiturn

Shaft version

- V Solid shaft

Data format

- P PROFIBUS