

## Features

- 1-channel
- WirelessHART Adapter
- Battery operated
- Also supplies field device
- Input 2-wire HART transmitters and 2-wire HART current sources
- Output WirelessHART wireless interface
- Direct mounting on HART- or 4 mA ... 20 mA field device
- Rotatable antenna

## Function

The device upgrades a conventional HART or 4 mA ... 20 mA field device with a WirelessHART interface. It is mounted either directly to the cable gland entry or separated from the field device.

The device contains a battery pack which also powers the field device. Depending on the parameterization, battery lifetimes up to 5 years are possible. This allows autonomous measurements. The rotatable antenna can be brought in the optimal position, regardless of the mounting orientation of the field device.

The unit is easily programmed with a configuration tool (DTM or DD).

For additional information, refer to the manual and [www.pepperl-fuchs.com](http://www.pepperl-fuchs.com).

## Application

The batteries are not included with delivery. Please order separately.

## Assembly

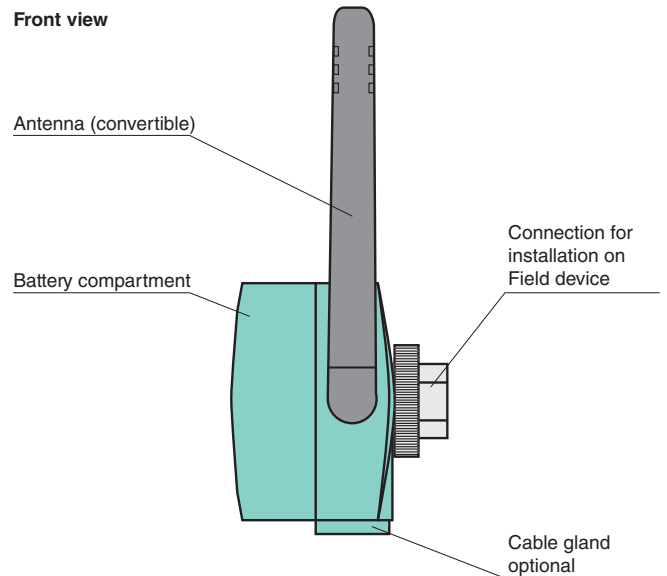

**WirelessHART**

## Connection

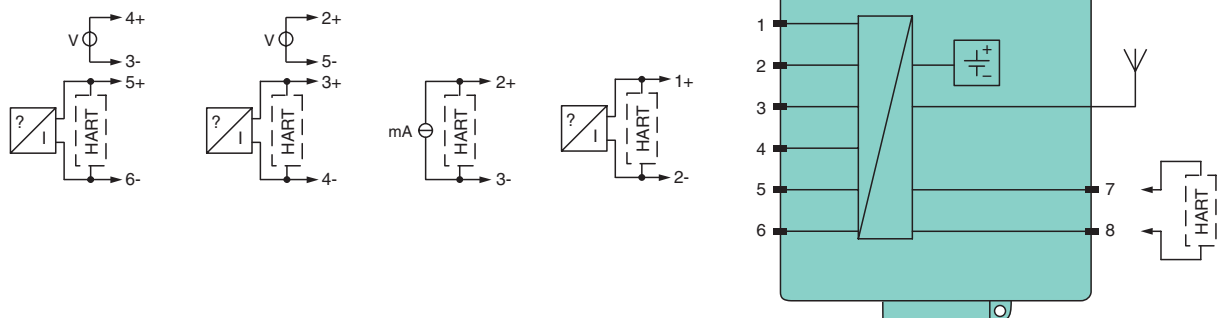

<b>Supply</b>	
Rated voltage	7.2 V DC , battery operated
<b>Electrical specifications</b>	
Output rated operating current	4 ... 20 mA
Supply	loop power for field devices voltage 8 ... 23 V DC, adjustable in steps of 0.1 V
<b>Input</b>	
Connectable field devices	usable for: - one point-to-point connection with a HART field device, or - one point-to-point connection with a 4 ... 20 mA field device, or - up to four externally powered HART field devices operating in multidrop mode
Connection	terminals 1, 2, 3, 4, 5, 6 multiple wirings available , depending on operating mode
Current	4 ... 20 mA
<b>HART communication</b>	
Protocol	HART 7.1, backward compatible
Number of devices	- one passive 4 ... 20 mA/HART field device - up to 4 HART field devices in multidrop mode
Transfer rate	1200 Bit/s
Parameters	primary/secondary master, preambles, retries and short address scan ranges
<b>Output</b>	
Interface	omnidirectional dipole antenna, adjustable in vertical plane
Output variables	PV: loop current SV, TV, QV:configurable according to user requirement - adapter: temperature, battery voltage, energy consumed and estimated battery life-time - 4 ... 20 mA device: scaled or linearized process value - HART device: up to four process variables
Communication	WirelessHART specifications - physical layer: IEEE 802.15.4.2006 - frequency band: 2.4 GHz (ISM band, licence free) - transmission rate: 250 kBit/s - max. transmit power: +10 dBm (EIRP) - transmission range: outdoor 250 m, indoor 50 m (under reference conditions) - communication standard: WirelessHART
<b>Transfer characteristics</b>	
Accuracy	current input: 0.125 % of measuring range
Influence of ambient temperature	current input: 5 µA/K
<b>Indicators/settings</b>	
Parameter assignment	- wireless transmit power: configurable to 0 dBm or 10 dBm (EIRP) - device variables mapping - publishing of up to ten burst messages in a wireless network, period and trigger mode selectable - notification of up to five events from adapter and/or connected device(s) in a wireless network - scaling and linearization of 4 ... 20 mA signal of connected analog device - tuning of supply parameters for the connected device - locking/unlocking of device parameterization
<b>Directive conformity</b>	
<b>Electromagnetic compatibility</b>	
Directive 2004/108/EC	EN 61326-1:2006
Radio and telecommunication terminal equipment	The usage of 2.4 GHz equipment is bound to local restrictions. Ensure that restrictions allow usage of this product before commissioning.
Directive 99/5/EC	ETSI EN 300328: V1.7.1 (2006-10), ETSI EN 301489-17: V1.2.1 (2002-08), EN 60950:2001
FCC CFR47 Part 15 B and C	ANSI C63.4-2003
<b>Conformity</b>	
Protection degree	IEC 60529
Shock resistance	EN 60068-2-27
Vibration resistance	EN 60068-2-64
<b>Ambient conditions</b>	
Ambient temperature	-40 ... 80 °C (-40 ... 176 °F)
Storage temperature	-40 ... 85 °C (-40 ... 185 °F)
Relative humidity	max. 90 % , noncondensing
Vibration resistance	20 ... 2000 Hz, 0,01 g <sup>2</sup> /Hz
Impact resistance	15 g, 11 ms
Corrosion resistance	acc. to ISA-S71.04-1985, severity level G3 test setup and execution acc. to EN 60068-2-60
<b>Mechanical specifications</b>	
Protection degree	IP66
Cable entry	M20 x 1.5 ; enclosed cable gland
Material	plastic
Mass	approx. 750 g

Release date 2012-08-30 12:49 Date of issue 2012-08-30 146566\_eng.xml

Dimensions	91 x 88.5 x 100.6 mm (3.6 x 3.5 x 4 in) (without cable glands and antenna)
Mounting	mounting on field device , panel or pole mounting versions see type code
<b>General information</b>	
Supplementary information	EC-Type Examination Certificate, Statement of Conformity, Declaration of Conformity, Attestation of Conformity and instructions have to be observed where applicable. For information see <a href="http://www.pepperl-fuchs.com">www.pepperl-fuchs.com</a> .
<b>Accessories</b>	
Designation	- battery W-BAT-B2-Li (order separately) - mounting set W-ACC-MKF8

**Product versions**

Designation	Description
WHA-ADP-F8B2-N-PP-GP-1	Mounts in 1/2" thread on Field Device
WHA-ADP-F8B2-T-PP-GP-1	Mounts in 3/4" thread on Field Device
WHA-ADP-F8B2-P-PP-GP-1	Mounts in PG thread on Field Device
WHA-ADP-F8B2-S-PP-GP-1	Mounts in M20 thread on Field Device
WHA-ADP-F8B2-0-PP-GP-1	Mounting seperated from Field Device with Mounting Kit
WHA-ADP-F8B2-0-P0-GP	Repeater with Mounting Kit